

Close Nippled Combinations – 14 Miniature Series

• See individual component pages for details.

Two-Unit Combo

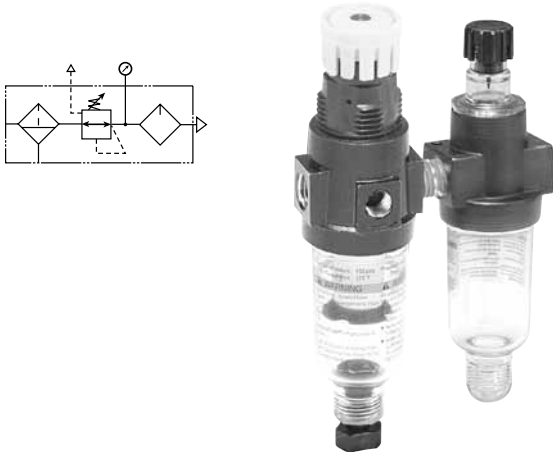

Series	Port	Model Numbers
14G	1/8"	14G01B13F0G*
	1/4"	14G11B13F0G*

For other models, refer to ordering information on next page.
 For polycarbonate bowl see Caution on inside cover.

A	B	C	D	E	F
3.75 (95)	3.79 (96)	2.42 (61)	2.04 (52)	6.21 (158)	.79 (20)

Inches (mm)
 Note: All dimensions nominal.

Three-Unit Combo

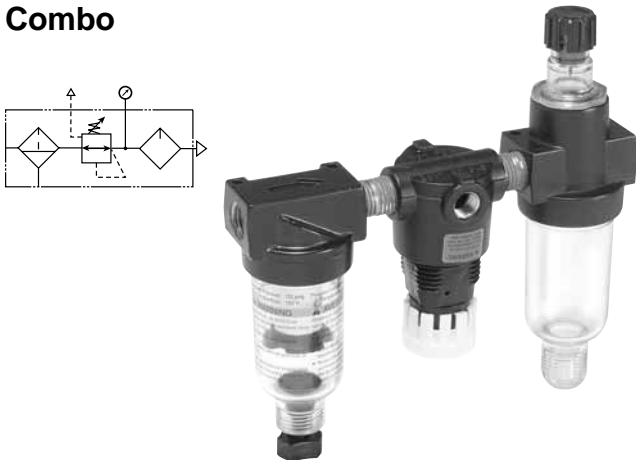

Series	Port	Model Numbers
14A	1/8"	14A01B13F0G*
	1/4"	14A11B13F0G*

For other models, refer to ordering information on next page.
 For polycarbonate bowl see Caution on inside cover.

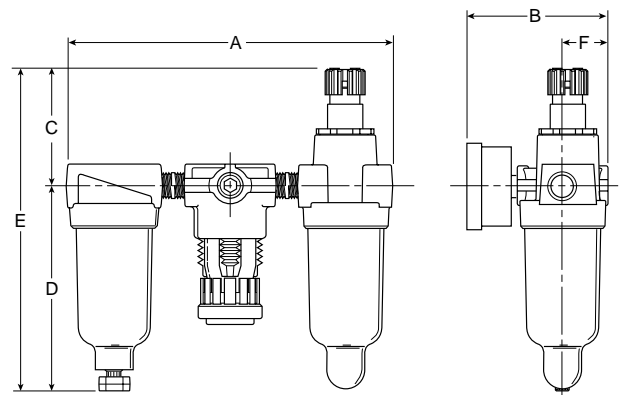

A	B	C	D	E	F
5.77 (147)	3.82 (97)	2.16 (55)	2.04 (52)	5.98 (152)	.79 (20)

Inches (mm)
 Note: All dimensions nominal.

BOLD ITEMS ARE MOST POPULAR.



Close Nippled Combinations – 14 Miniature Series

Ordering Information

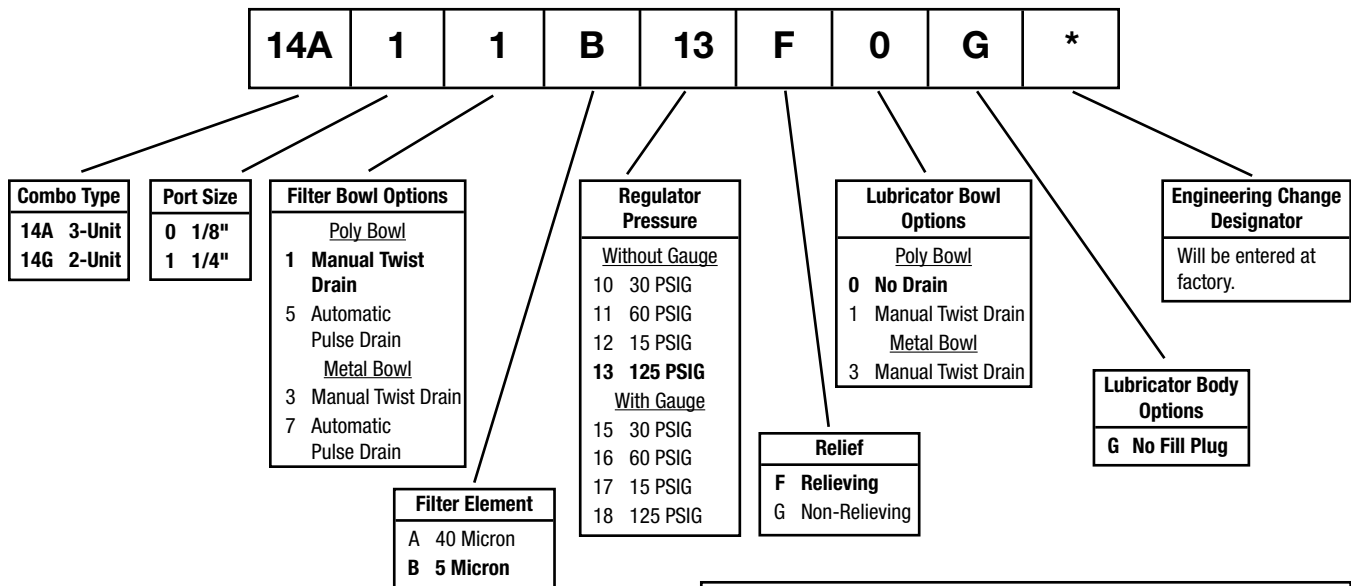

⚠ WARNING
Product rupture can cause serious injury.
Do not connect regulator to bottled gas.
Do not exceed maximum primary pressure rating.

⚠ CAUTION:
REGULATOR PRESSURE ADJUSTMENT – The working range of knob adjustment is designed to permit outlet pressures within their full range. Pressure adjustment beyond this range is also possible because the knob is not a limiting device. This is a common characteristic of most industrial regulators, and limiting devices may be obtained only by special design. For best performance, regulated pressure should always be set by increasing the pressure up to the desired setting.

Mounting Bracket Kits

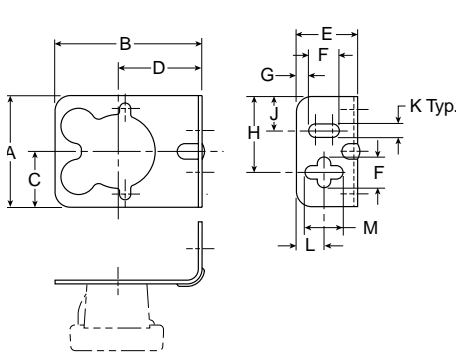

PS417B
 (Includes Panel Mount Nut)

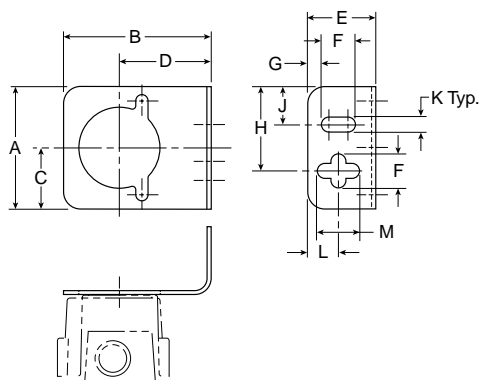

PS419

Dimensions

A	B	C	D	E	F	G	H	J	K	L	M	Kit
1.80 (46)	2.37 (60)	.90 (23)	1.35 (34)	1.00 (25)	.50 (13)	.20 (5)	1.24 (31)	.56 (14)	.22 (6)	.45 (11)	.62 (16)	PS417B (14F, 10F, 14R, 14E)
1.80 (46)	2.17 (55)	.90 (23)	1.35 (34)	1.00 (25)	.50 (13)	.20 (5)	1.24 (31)	.56 (14)	.22 (6)	.45 (11)	.62 (16)	PS419 (04L)

Inches (mm)
 Note: All dimensions nominal.