

15R Regulators – Economy

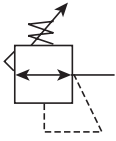

Features

- Solid control piston with resilient seat for service-free operation.
- Non-rising “locking” adjusting knob.
- Compact, 3.30 inch (84mm) high by 2.12 inch (54mm) wide.
- Easily serviced.
- High Flow: 1/4" – 21 SCFM[§]
 3/8" – 28 SCFM[§]

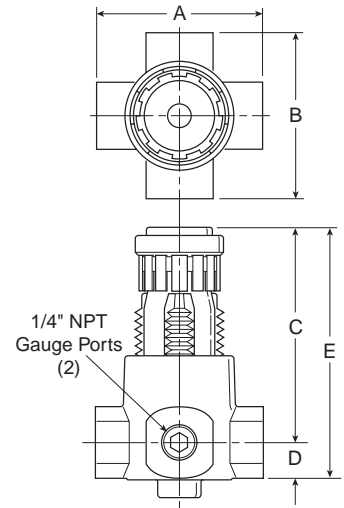

Port Size	NPT
Without Gauge	
1/4"	15R113F*
3/8"	15R213F*
With Gauge	
1/4"	15R118F*
3/8"	15R218F*

15R Regulator Dimensions		
A	B	C
2.12 (54)	2.00 (51)	2.60 (66)
D	E	
0.70 (18)	3.30 (84)	

Inches (mm)

Standard part numbers shown bold. For other models refer to ordering information below.

NOTE: 1.218 Dia. (31mm) hole required for panel mounting.

§.SCFM = Standard cubic feet per minute at 100 PSIG inlet, 90 PSIG no flow secondary setting and 10 PSIG pressure drop.

Ordering Information

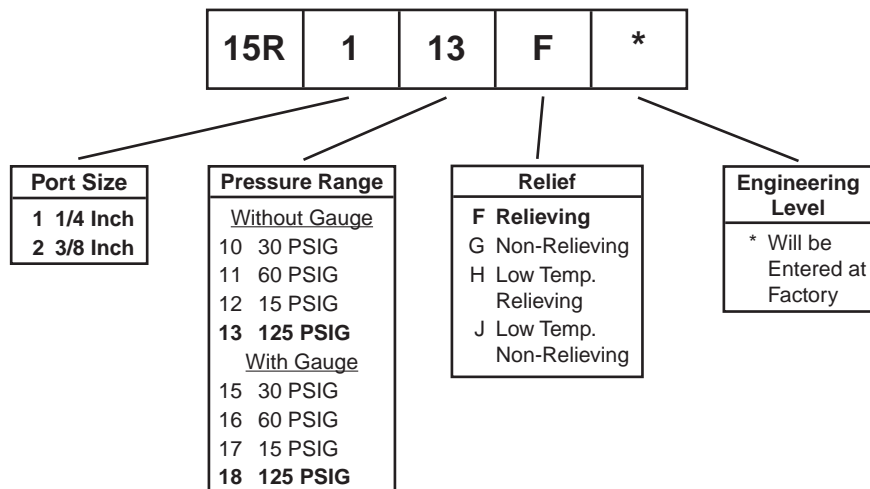

BOLD ITEMS ARE MOST POPULAR.

Technical Information

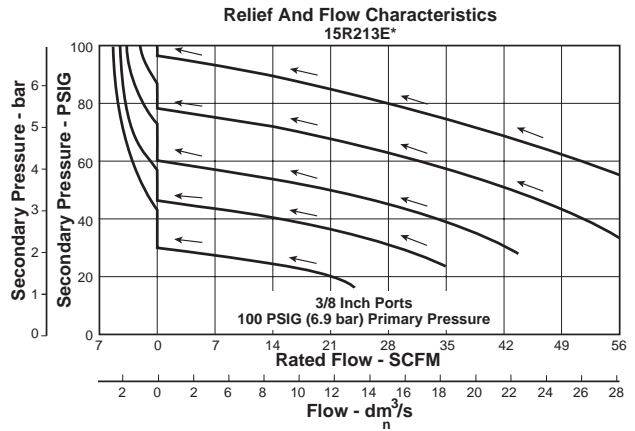
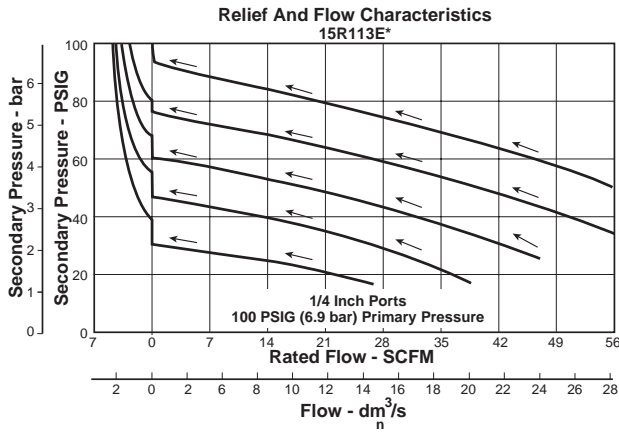

⚠ WARNING
 Product rupture can cause serious injury.
 Do not connect regulator to bottled gas.
 Do not exceed maximum primary pressure rating.

⚠ CAUTION:
REGULATOR PRESSURE ADJUSTMENT – The working range of knob adjustment is designed to permit outlet pressures within their full range. Pressure adjustment beyond this range is also possible because the knob is not a limiting device. This is a common characteristic of most industrial regulators, and limiting devices may be obtained only by special design. For best performance, regulated pressure should always be set by increasing the pressure up to the desired setting.

15R Regulator Kits & Accessories

- Body Service Kit – UnbalancedPS424BP
- Bonnet Assembly Kit L01369
- Gauges – 30 PSIG, 1/8" NPT (0 to 2.1 bar) K4515N18030
- 60 PSIG, 1/8" NPT (0 to 4.1 bar) K4515N18060
- 160 PSIG, 1/8" NPT (0 to 11.0 bar) K4515N18160
- 60 PSIG, 1/4" NPT (0 to 4.1 bar) K4520N14060
- 160 PSIG, 1/4" NPT (0 to 11.0 bar) K4520N14160
- Mounting Bracket Kit (Includes Panel Mount Nut).....PS417BP
- Panel Mount Nuts – Plastic..... P78652
- Metal P01531
- Service Kits – Non-Relieving PS422P
- Relieving PS423P
- Springs – 1-15 PSIG Range (Yellow) P01176
- 1-30 PSIG Range (Black) P01175
- 1-60 PSIG Range (White) P01174
- 2-125 PSIG Range (Gold) P01173

Specifications

- Gauge Ports (2) 1/4 Inch
 (Can be used for Full Flow)
- Port Threads 1/4, 3/8 Inch
- Pressure & Temperature Ratings – 0 to 250 PSIG (0 to 17.2 bar)
 32°F to 125°F (0°C to 52°C)
- Low Temperature -4°F to 125°F (-20°C to 52°C)
- Secondary Pressure Ranges –
- Standard Pressure..... 2 to 125 PSIG (0 to 8.6 bar)
- Medium Pressure 1 to 60 PSIG (0 to 4.1 bar)
- Medium Pressure 1 to 30 PSIG (0 to 2.1 bar)
- Low Pressure..... 1 to 15 PSIG (0 to 1 bar)
- Weight0.5 lb. (0.23 kg)

Materials of Construction

- Adjusting Nut.....Brass
- Adjusting Stem & SpringSteel
- Body Zinc
- Bonnet, Seat, Piston & Valve Poppet Plastic
- SealsNitrile

