

**⚠ WARNING**

To avoid unpredictable system behavior that can cause personal injury and property damage:

- Disconnect electrical supply (when necessary) before installation, servicing, or conversion.
- Disconnect air supply and depressurize all air lines connected to this product before installation, servicing, or conversion.
- Operate within the manufacturer's specified pressure, temperature, and other conditions listed in these instructions.
- Medium must be moisture-free if ambient temperature is below freezing.
- Service according to procedures listed in these instructions.
- Installation, service, and conversion of these products must be performed by knowledgeable personnel who understand how pneumatic products are to be applied.
- After installation, servicing, or conversion, air and electrical supplies (when necessary) should be connected and the product tested for proper function and leakage. If audible leakage is present, or the product does not operate properly, do not put into use.
- Warnings and specifications on the product should not be covered by paint, etc. If masking is not possible, contact your local representative for replacement labels.

**⚠ WARNING**

Product rupture can cause serious injury.  
 Do not connect regulator to bottled gas.  
 Do not exceed maximum primary pressure rating.

**Safety Guide**

For more complete information on recommended application guidelines, see the Safety Guide section of Pneumatic Division catalogs or you can download the **Pneumatic Division Safety Guide** at: [www.parker.com/pneumatics](http://www.parker.com/pneumatics)

**Introduction**

Follow these instructions when installing, operating, or servicing the product.

**Application Limits**

These products are intended for use in general purpose compressed air systems only.

<b>Operating Pressure Maximum</b>	<b>kPa</b>	<b>PSIG</b>	<b>bar</b>
	2068	300	21.0
<b>Operating Temperature Range</b>	(40° to 150°F) 4°C to 66°C		

**ANSI Symbol**

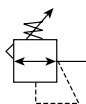

**Installation**

1. The Regulator should be installed with reasonable accessibility for service whenever possible – repair service kits are available. Keep pipe or tubing lengths to a minimum with inside clean and free of dirt and chips. Pipe joint compound should be used sparingly and applied only to the male pipe – never into the female port. Do not use PTFE tape to seal pipe joints – pieces have a tendency to break off and lodge inside the unit, possibly causing malfunction. Also, new pipe or hose should be installed between the Filter / Regulator and equipment being protected.

2. The upstream pipe work must be clear of accumulated dirt and liquids.
3. Select a Regulator location as close as possible to the equipment being protected.
4. Install Regulator so that air flows into port labelled “IN” on body.
5. Gauge ports are located on both sides of the Regulator body for your convenience. It is necessary to install a gauge or socket pipe plugs into each port during installation.

**Operation**

1. Before turning on the air supply, engage the R10 Adjusting Knob by pushing down. Turn R10 Adjusting Knob or R11 T-handle counterclockwise until the compression is released from the Pressure Control Spring.
2. Then turn R10 Knob or R11 T-handle clockwise and adjust regulator to desired downstream pressure. This permits pressure to build up slowly in the downstream line.
3. To decrease regulated pressure settings, always reset from a pressure lower than the final setting required. Example, lowering the secondary pressure from 550 to 410 kPa (80 to 60 PSIG) is best accomplished by dropping the secondary pressure to 350 kPa (50 PSIG), then adjusting upward to 410 kPa (60 PSIG).
4. When desired secondary pressure setting has been reached, pull the R10 Knob up or tighten the R11 Lock Nut to lock this pressure setting.

**Maintenance**

To clean regulator, it is not necessary to remove the unit from the airline. Use a filter in line prior to the regulator to keep the air supply clean. If using compressed air to blow dry, be sure to wear appropriate eye protection. Wipe parts clean with soapy water or denatured alcohol. Torque Spring Cage and Bottom Plug before using.

**⚠ Caution: Never use solvents like carbon tetrachloride, acetone or thinner to clean parts.**

**⚠ WARNING**

**FAILURE OR IMPROPER SELECTION OR IMPROPER USE OF THE PRODUCTS AND/OR SYSTEMS DESCRIBED HEREIN OR RELATED ITEMS CAN CAUSE DEATH, PERSONAL INJURY AND PROPERTY DAMAGE.**

This document and other information from The Company, its subsidiaries and authorized distributors provide product and/or system options for further investigation by users having technical expertise. It is important that you analyze all aspects of your application, including consequences of any failure and review the information concerning the product or systems in the current product catalog. Due to the variety of operating conditions and applications for these products or systems, the user, through its own analysis and testing, is solely responsible for making the final selection of the products and systems and assuring that all performance, safety and warning requirements of the application are met.

The products described herein, including without limitation, product features, specifications, designs, availability and pricing, are subject to change by The Company and its subsidiaries at any time without notice.

**EXTRA COPIES OF THESE INSTRUCTIONS ARE AVAILABLE FOR INCLUSION IN EQUIPMENT / MAINTENANCE MANUALS THAT UTILIZE THESE PRODUCTS. CONTACT YOUR LOCAL REPRESENTATIVE.**

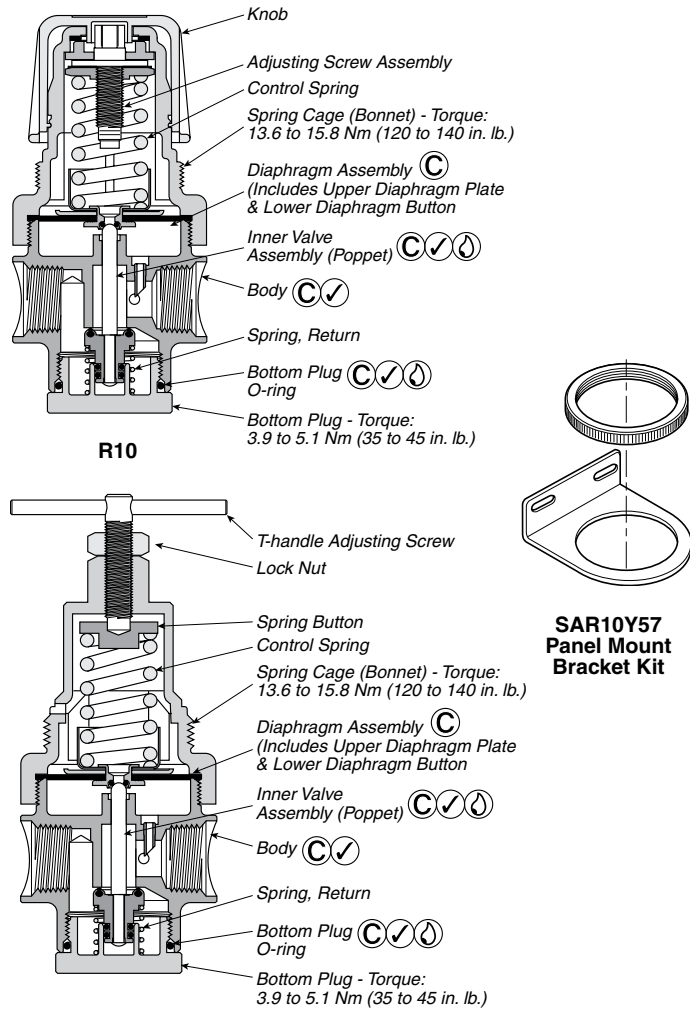

Figure 1

- ① Lightly grease with provided lubricant.
- ✓ Inspect for nicks, scratches, and surface imperfections. If present, reduced service life is probable and future replacement should be planned.
- Ⓒ Clean with lint-free cloth.

**Service**

**⚠ Caution: Disconnect or shut off air supply and exhaust the primary and secondary pressures before servicing unit. Turning the adjusting knob or T-handle counterclockwise does not vent downstream pressure on non-relieving regulators. Downstream pressure must be vented before servicing regulator.**

**⚠ Caution: Grease packets are supplied with kits for lubrication of seals. Use only mineral based grease or oils. Do not use synthetic oils such as esters. Do not use silicones.**

**Note: After servicing unit, turn on air supply and adjust regulator to the desired downstream pressure. Check unit for leaks. If leakage occurs, do not operate - conduct repairs and retest.**

**Servicing Regulator - (Refer to Figure 1)**

1. Engage the R10 Adjusting Knob by pushing down. Turn R10 Adjusting Knob counterclockwise until the compression is released from the Pressure Control Spring.
2. On the R11, loosen Lock Nut and turn R11 T-handle counterclockwise until the compression is released from the Pressure Control Spring.
3. Remove the Bonnet Assembly by unscrewing the Bonnet from the Body.

4. Remove Diaphragm Assembly from Bonnet Assembly.
5. Remove Bottom Plug, Bottom Plug O-ring, Poppet Assembly, and Return Spring.
6. Clean and carefully inspect parts for wear or damage. If replacement is necessary, use parts from service kits.
7. Lubricate O-rings with grease found in service kits.

**Replacement Parts**

Part Number	Description
R10Y54	Adjusting Knob
SPR-387	"A" Range Control Spring, 0 to 25 PSI (0 to 1.7 bar)
SPR-388	"B" Range Control Spring, 0 to 60 PSI (0 to 4.1 bar)
SPR-389	"C" Range Control Spring, 0 to 125 PSI (0 to 8.5 bar)
SPR-390	"D" Range Control Spring, 0 to 250 PSI (0 to 17 bar)
F10Y103-1	Bottom Plug O-ring (Standard) (+X8)
F10Y103-2VT	Bottom Plug O-ring (Viton)
R10Y2-Z5	Bottom Plug (Brass)
R10Y2-P	Bottom Plug (Plastic)
R10X51	Panel Mount Nut
R10Y57	Panel Mount Bracket
SPR-391-1	Return Spring

**Service Kits Available**

Part Number	Description	
CKR10Y	Spring Cage Kit (Includes Adjusting Screw, Spring Cage, & Adjusting Knob)	
RKR10Y	Relieving Repair Kit (Standard)	(Includes: Diaphragm Assy, Inner Valve Assy, & Bottom Plug O-ring)
RKR10YX64	Relieving Repair Kit (Viton)	
RKR10YX8	Relieving Repair Kit (EPDM)	
RKR10KY	Non-Relieving Repair Kit (Standard)	
RKR10KYX64	Non-Relieving Repair Kit (Viton)	
RKR10KYX8	Non-Relieving Repair Kit (EPDM)	
SAR10Y57	Panel Mount Bracket Kit (Includes Panel Mount Nut & Panel Mount Bracket)	
CKR11Y	Spring Cage Kit (Includes Spring Cage, Lock Nut, Adjusting Screw Assembly, & Spring Button)	

**Dimensions**

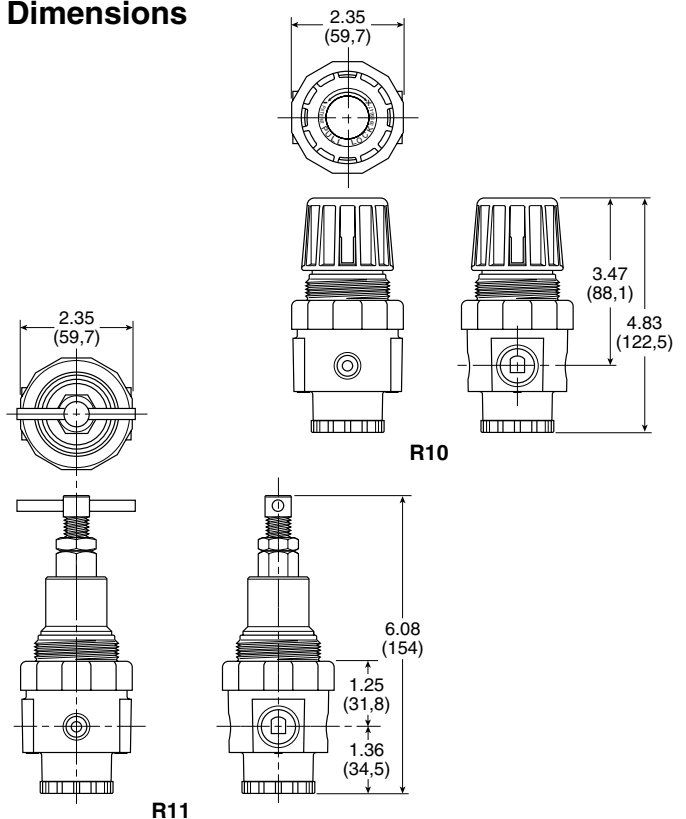

R11