

- Ⓓ Lightly grease with provided lubricant.
- ✓ Inspect for nicks, scratches, and surface imperfections. If present, reduced service life is probable and future replacement should be planned.
- Ⓒ Clean with lint-free cloth.

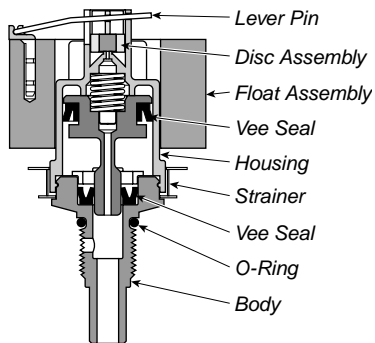

Internal Auto Drain

⚠ CAUTION

Polycarbonate bowls, being transparent and tough, are ideal for use with Filters and Lubricators. They are suitable for use in normal industrial environments, but should not be located in areas where they could be subjected to direct sunlight, an impact blow, nor temperatures outside of the rated range. As with most plastics, some chemicals can cause damage. Polycarbonate bowls should not be exposed to chlorinated hydrocarbons, ketones, esters and certain alcohols. They should not be used in air systems where compressors are lubricated with fire-resistant fluids such as phosphate ester and diester types.

Metal bowls are recommended where ambient and/or media conditions are not compatible with polycarbonate bowls. Metal bowls resist the action of most such solvents, but should not be used where strong acids or bases are present or in salt laden atmospheres. Consult the factory for specific recommendations where these conditions exist.

TO CLEAN POLYCARBONATE BOWLS USE MILD SOAP AND WATER ONLY! DO NOT use cleansing agents such as acetone, benzene, carbon tetrachloride, gasoline, toluene, etc., which are damaging to this plastic.

Service Kits / Parts Available

Description	Kit Number
Element Replacement Kit 5 Micron Element 40 Micron Element	EKF20VA EKF20A
Sight Gauge Repair Kit (Sight Gauge, Sight Gauge O-Ring, Indicator Float, Sight Gauge Retainer, Retainer O-Ring)	RKB605WB
Bowl, Replacement Kit w/Drain Cock (Bowl and Sight Gauge, Bowl O-Ring)	BKF21WA*
Internal Auto Drain Repair Kit (Lever Pin, Disc Assembly, Float Assembly, Vee Seal, Strainer, O-Ring)	RK602MD/M4
Piston Drain Kit (Piston, Drain Cock Complete Assembly including Strainer and O-Ring)	4212

* Bowl kit without manual drain no longer available (use BKF21WA).

Accessories

Description	Kit Number
Wall Mount Kit	MK20-0100

Extra (Pipe Port) Insert Kits and Combination Unit Interface Insert

Pipe Port Size	Kit Number
1/4"	IK20Y
3/8"	IK20X
1/2"	IK20A
3/4"	IK20B
1"	IK20C
Combination	IK20CC

Note: Kit includes two pipe port inserts. "O" rings and pins.

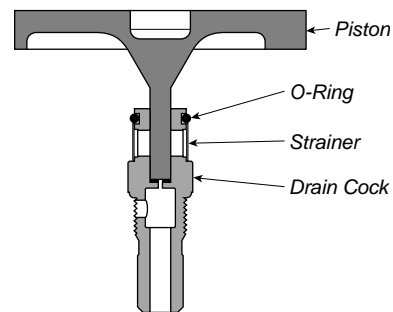

Piston Drain

⚠ WARNING

FAILURE OR IMPROPER SELECTION OR IMPROPER USE OF THE PRODUCTS AND/OR SYSTEMS DESCRIBED HEREIN OR RELATED ITEMS CAN CAUSE DEATH, PERSONAL INJURY AND PROPERTY DAMAGE.

This document and other information from The Company, its subsidiaries and authorized distributors provide product and/or system options for further investigation by users having technical expertise. It is important that you analyze all aspects of your application, including consequences of any failure and review the information concerning the product or systems in the current product catalog. Due to the variety of operating conditions and applications for these products or systems, the user, through its own analysis and testing, is solely responsible for making the final selection of the products and systems and assuring that all performance, safety and warning requirements of the application are met.

The products described herein, including without limitation, product features, specifications, designs, availability and pricing, are subject to change by The Company and its subsidiaries at any time without notice.

EXTRA COPIES OF THESE INSTRUCTIONS ARE AVAILABLE FOR INCLUSION IN EQUIPMENT / MAINTENANCE MANUALS THAT UTILIZE THESE PRODUCTS. CONTACT YOUR LOCAL REPRESENTATIVE.