

C35 Combination Units

Two Unit Combo

A

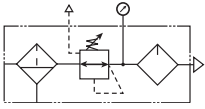

- 20 Micron Filter Element
- Manual Twist Drain
- Relieving Regulator
- 125 PSI (8.6 bar)
- Gauge Included

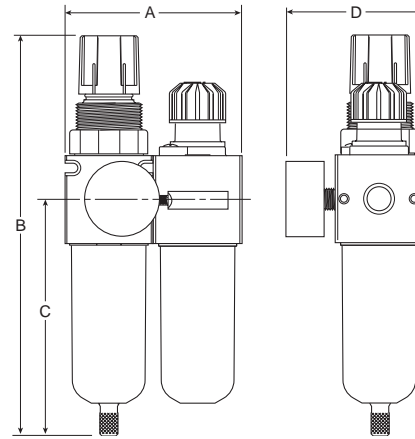

Port Size	Model Numbers
1/8"	C35-01BLAHCA
1/4"	C35-02BLAHCA

A	B	C	D
3.19 (80.9)	7.00 (177.8)	4.25 (107.9)	2.88 (73)

Inches
(mm)

For other models refer to ordering information on next page.

Three Unit Combo

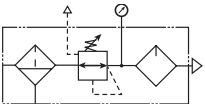

- 20 Micron Filter Element
- Manual Twist Drain
- Relieving Regulator
- 125 PSI (8.6 bar)
- Gauge Included

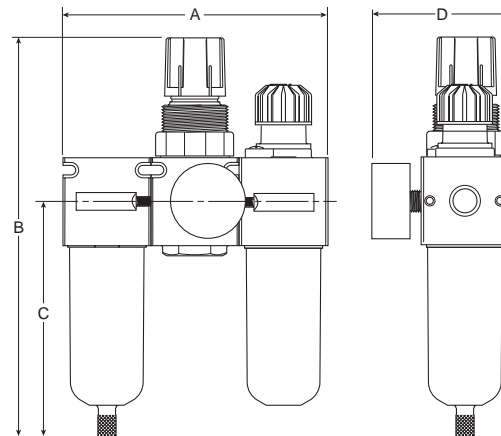

Port Size	Model Numbers
1/8"	C35-01FRLAHCA
1/4"	C35-02FRLAHCA

A	B	C	D
4.78 (121.4)	7.00 (177.8)	4.25 (107.9)	2.88 (73)

Inches
(mm)

For other models refer to ordering information on next page.

Ordering Information

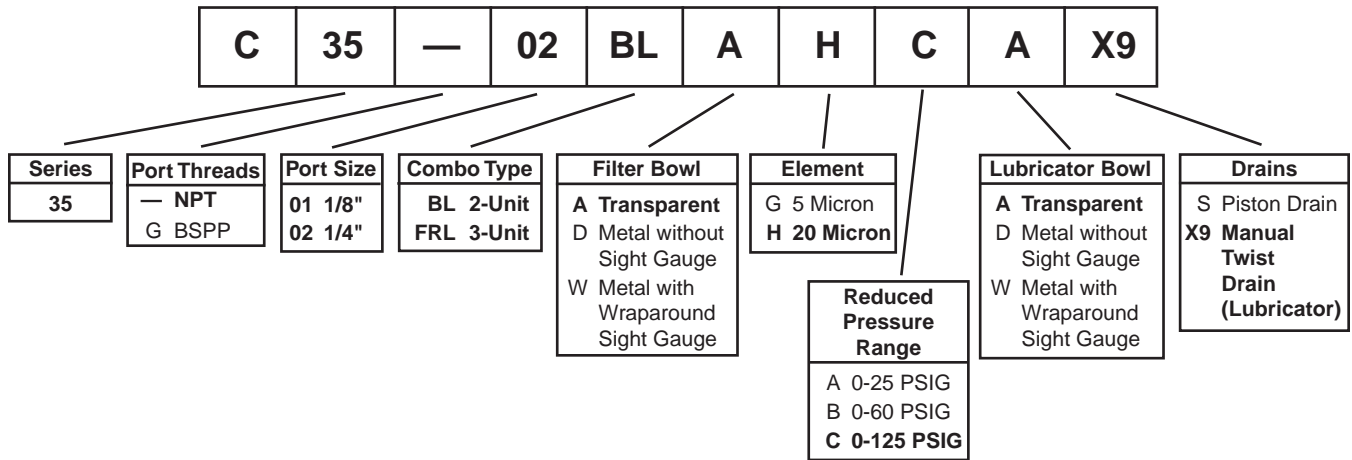

BOLD ITEMS ARE MOST POPULAR.

⚠ WARNING
<p>Product rupture can cause serious injury. Do not connect regulator to bottled gas. Do not exceed maximum primary pressure rating.</p>

⚠ CAUTION:
<p>REGULATOR PRESSURE ADJUSTMENT – The working range of knob adjustment is designed to permit outlet pressures within their full range. Pressure adjustment beyond this range is also possible because the knob is not a limiting device. This is a common characteristic of most industrial regulators, and limiting devices may be obtained only by special design. For best performance, regulated pressure should always be set by increasing the pressure up to the desired setting.</p>

**C35 Combination Units
 Kits & Accessories**

Mounting Bracket Kit (2 Required)SAR35Y57
 See individual component sections for other kits and accessories.

Bracket Installation

