

C75 Combination Units

Two Unit Combo

A

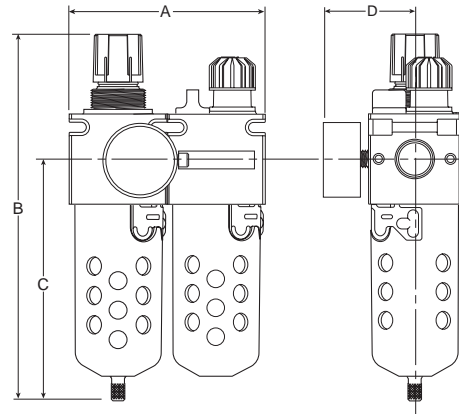
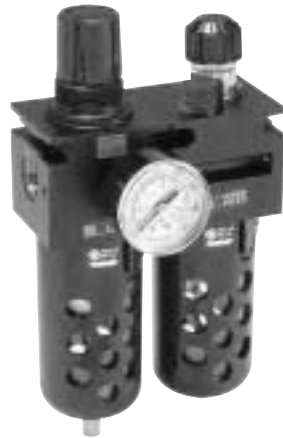
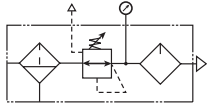

- 40 Micron Filter Element
- Manual Twist Drain
- Relieving Regulator
- 125 PSI (8.6 bar)
- Gauge Included

Port Size	Model Numbers
1/4"	C75-02BLBJCB
3/8"	C75-03BLBJCB
1/2"	C75-04BLBJCB

A	B	C	D
C75-BL - B & D Bowls			
4.19 (106.4)	7.97 (202.4)	5.19 (131.8)	3.44 (81.7)
C75-BL - W Bowls			
4.19 (106.4)	8.23 (208.9)	5.44 (138.2)	3.44 (87.3)

Inches
(mm)

For other models refer to ordering information on next page.

Three Unit Combo

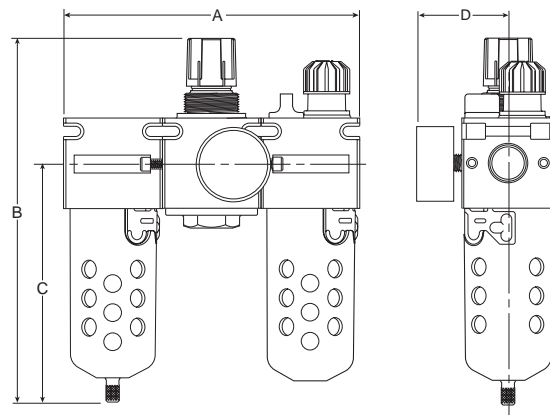
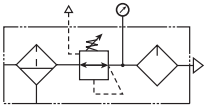

- 40 Micron Filter Element
- Manual Twist Drain
- Relieving Regulator
- 125 PSI (8.6 bar)
- Gauge Included

Port Size	Model Numbers
1/4"	C75-02FRLBJCB
3/8"	C75-03FRLBJCB
1/2"	C75-04FRLBJCB

A	B	C	D
C75-BL - B & D Bowls			
6.57 (166.9)	7.97 (202.4)	5.19 (131.8)	3.44 (81.7)
C75-BL - W Bowls			
6.57 (166.9)	8.06 (204.7)	5.31 (134.9)	3.44 (87.3)

Inches
(mm)

For other models refer to ordering information on next page.

Ordering Information

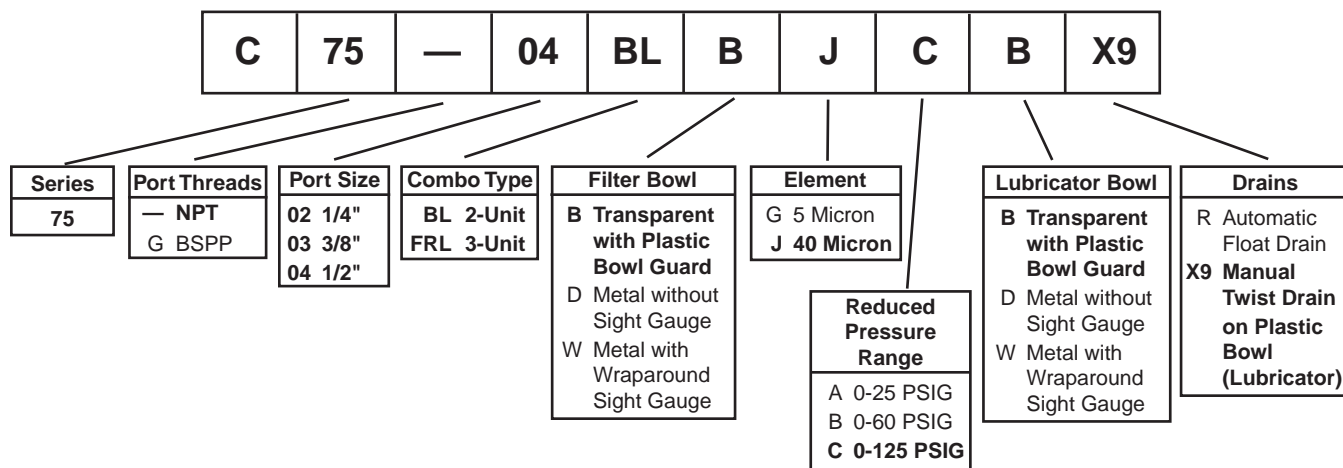

BOLD ITEMS ARE MOST POPULAR.

⚠ WARNING
Product rupture can cause serious injury. Do not connect regulator to bottled gas. Do not exceed maximum primary pressure rating.

⚠ CAUTION:
REGULATOR PRESSURE ADJUSTMENT – The working range of knob adjustment is designed to permit outlet pressures within their full range. Pressure adjustment beyond this range is also possible because the knob is not a limiting device. This is a common characteristic of most industrial regulators, and limiting devices may be obtained only by special design. For best performance, regulated pressure should always be set by increasing the pressure up to the desired setting.

Polyurethane Bowls and Sight Gauges Offer Improved Chemical Compatability.

**C75 Combination Units
 Kits & Accessories**

Mounting Bracket Kit (2 Required)SAR75Y57
 See individual component sections for other kits and accessories.

Bracket Installation

