

**R10, R11 Regulator – Standard**

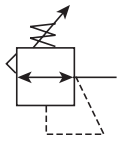

**Features**

- Stainless Steel Construction Handles Most Corrosive Environments
- Large Daphragm to Valve Area Ratio for Precise Regulation and High Flow Capacity
- Meets NACE Specifications MR-01-75/ISO 15156
- Low Temperature Version Available
- High Flow: 1/2" – 80 SCFM<sup>§</sup>



R11



R10

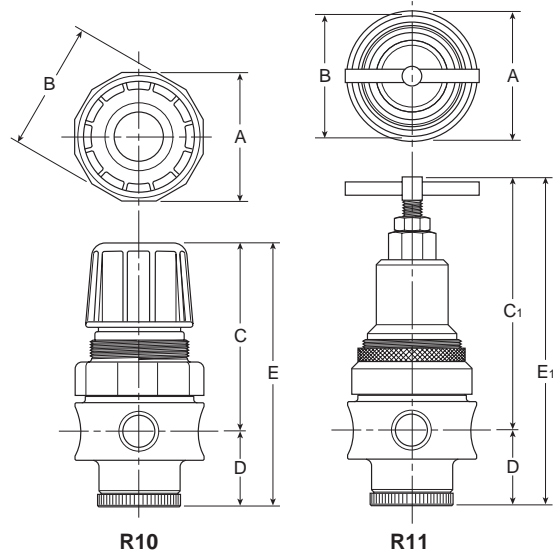

Series	Adjustment Type	Port Size	NPT	BSPB
R10	Knob	1/2"	<b>R10-04CSS</b>	R10G04CSS
R11	Tee Handle	1/2"	<b>R11-04CSS</b>	R11G04CSS

R10, R11 Regulator Dimensions		
<b>A</b> 2.34 (60)	<b>B</b> 2.43 (62)	<b>C</b> 3.59 (91)
<b>C<sub>1</sub></b> 4.70 (119)	<b>D</b> 1.38 (35)	<b>E</b> 4.97 (126)
<b>E<sub>1</sub></b> 6.08 (154)		

Standard part numbers shown bold. For other models refer to ordering information below.

<sup>§</sup> SCFM = Standard cubic feet per minute at 100 PSIG inlet, 75 PSIG no flow secondary setting and 15 PSIG pressure drop.

**⚠ WARNING**

**Product rupture can cause serious injury.  
 Do not connect regulator to bottled gas.  
 Do not exceed maximum primary pressure rating.**

inches (mm)  
 NOTE: 1.75 Dia. (44mm) hole required for panel mounting.

**Ordering Information**

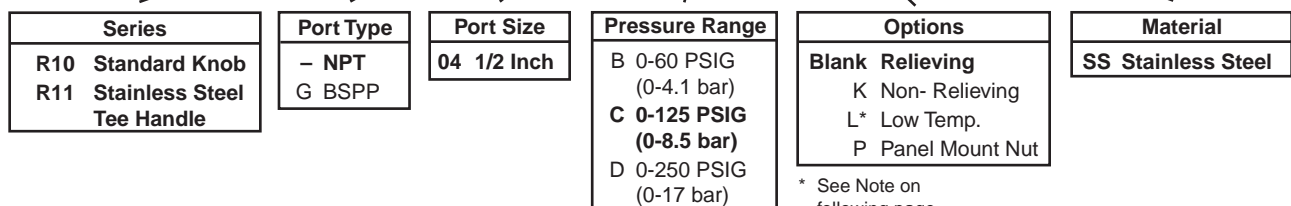
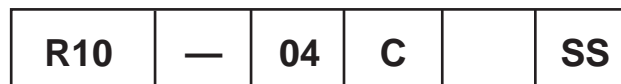

**BOLD ITEMS ARE MOST POPULAR.**

\* See Note on following page.

Operation

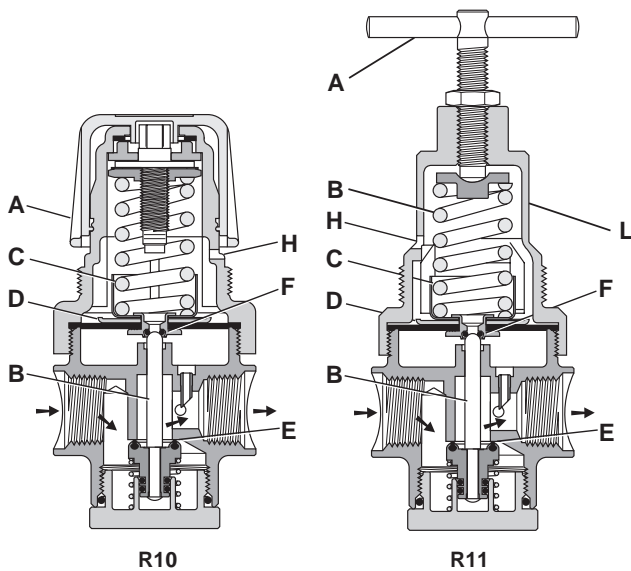

With the adjusting knob / Tee Handle (A) turned fully counter-clockwise (no spring load), and pressure supplied to the regulator inlet port, the valve poppet assembly (B) is closed. Turning the adjusting knob clockwise applies a load to control spring (C). This load causes the diaphragm (D) and the valve poppet assembly (B) to move downward allowing flow across the seat area (E) created between the poppet assembly and the seat. Pressure in the downstream line is sensed below the diaphragm (D) and offsets the load of spring (C). As downstream pressure rises, poppet assembly (B) and diaphragm (D) move upward until the area (E) is closed and the load of the spring (C) and pressure under diaphragm (D) are in balance. A reduced outlet pressure has now been obtained, depending on spring load. Creating a demand downstream, such as opening a valve, results in a reduced pressure under the diaphragm (D). The load of control spring (C) now causes the poppet assembly to move downward opening seat area (E) allowing air to flow to meet the downstream demand. The flow of downstream air is metered by the amount of opening (E). Should downstream pressure exceed the desired regulated pressure, the excess pressure will cause the diaphragm (D) to move upward against control spring (C), open vent hole (F), and vent the excess pressure to atmosphere through the hole in the bonnet (H). (This occurs in the relieving type regulator only.)

Technical Information

CAUTION:

REGULATOR PRESSURE ADJUSTMENT –

The working range of knob adjustment is designed to permit outlet pressures within their full range. Pressure adjustment beyond this range is also possible because the knob is not a limiting device. This is a common characteristic of most industrial regulators, and limiting devices may be obtained only by special design.

For best performance, regulated pressure should always be set by increasing the pressure up to the desired setting.

\* Note: “Low Temperature” option is intended for applications where the ambient temperature may be down to -40° C/F. Air supply must be free of moisture to prevent ice formation and malfunction of units. These units contain EPDM seals. Make sure any oils in the airstream are compatible.

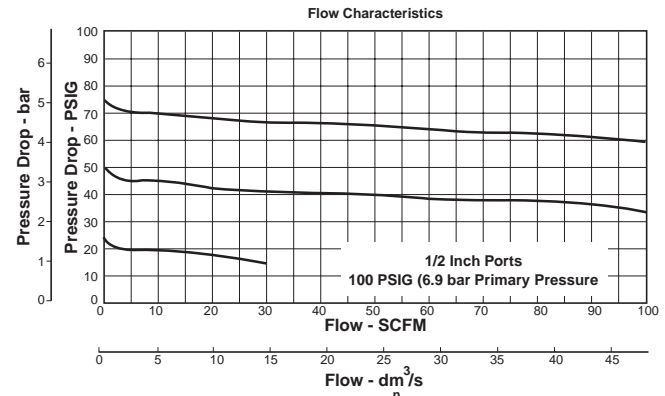

R10, R11 Regulator Kits & Accessories

R10 Bonnet Kit (Knob Included) .....	CKR10YSS
R11 Bonnet Kit.....	CKR11YSS
<b>Gauge (Stainless) –</b>	
160 PSIG (0 to 1100 kPa), 2" Face .....	K4520N14160SS
<b>Panel Mount Bracket (Stainless).....</b>	
R10Y57-SS	
<b>Panel Mount Nut –</b>	
Stainless .....	R10X51-SS
Plastic.....	R10X51-P
<b>Pipe Nipple –</b>	
1/2" 316 Stainless Steel .....	616A28-SS
<b>Service Kit –</b>	
Relieving.....	RKR10YSS
Non-Relieving.....	RKR10KYSS
<b>Springs –</b>	
0-60 PSIG Range .....	SPR-388-1-SS
0-125 PSIG Range .....	SPR-389-1-SS
0-250 PSIG Range .....	SPR-390-1-SS

Operation .....	Fluorocarbon Diaphragm
Port Threads .....	1/2 Inch
<b>Pressure &amp; Temperature Ratings –</b>	
R10 .....	300 PSIG Max (20.7 bar) 0°F to 150°F (-18°C to 66°C)
R11 .....	300 PSIG Max (20.7 bar) 0°F to 180°F (-18°C to 82°C)
Option “L” Minimum Operating Temperature .....	-40° C/F
<b>Note: Air must be dry enough to avoid ice formation at temperatures below 32°F (0°C).</b>	
Weight .....	1.79 lb. (0.81 kg)
<b>Materials of Construction</b>	
Adjustment Mechanism / Springs .....	316 Stainless Steel
Body .....	316 Stainless Steel
Bonnet / Tee Handle (R11).....	316 Stainless Steel
Bonnet / Knob (R10) .....	Acetal
Bottom Plug .....	316 Stainless Steel
Poppet .....	316 Stainless Steel
Seals .....	Fluorocarbon

Specifications

Gauge Port .....	1/4 Inch
------------------	----------

