

**! WARNING**

To avoid unpredictable system behavior that can cause personal injury and property damage:

- Disconnect electrical supply (when necessary) before installation, servicing, or conversion.
- Disconnect media source and depressurize all media lines connected to this product before installation, servicing, or conversion.
- Operate within the manufacturer's specified pressure, temperature, and other conditions listed in these instructions.
- Medium must be moisture-free if ambient temperature is below freezing.
- Service according to procedures listed in these instructions.
- Installation, service, and conversion of these products must be performed by knowledgeable personnel who understand how pneumatic products are to be applied.
- After installation, servicing, or conversion, media and electrical supplies (when necessary) should be connected and the product tested for proper function and leakage. If audible leakage is present, or the product does not operate properly, do not put into use.
- Warnings and specifications on the product should not be covered by paint, etc. If masking is not possible, contact your local representative for replacement labels.

**Introduction**

A unique feature of the QIX® series is the option of changing pipe size to accommodate 1/4" through 1" sizes. To change insert (prior to installation), simply remove both insert pins and pull insert in direction away from pin hole. Install new (size) insert or universal combination insert (for combination unit) ensuring O-ring is in place and insert is firmly seated prior to insert of pins. Follow these instructions when installing, operating, or servicing the product.

**Application Limits**

These products are intended for use in general purpose compressed media systems only.

**Operating Pressure:**

	kPa	PSIG	bar
Maximum Inlet Pressure	2068	300	21.0

**Ambient Temperature Range:**

4°C to 49°C  
 (40°F to 120°F)

**! WARNING**

Product rupture can cause serious injury.  
 Do not connect regulator to bottled gas.  
 Do not exceed maximum primary pressure rating.

**Symbols**

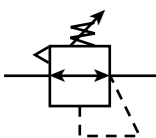

Relieving Regulator Adjustable

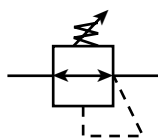

Non-Relieving Regulator Adjustable

**Installation**

Before installing, blow out pipe line to remove scale and other foreign matter. This unit has DRYSEAL pipe threads. Use pipe compound or tape sparingly to male threads only. Install regulator in pipe line so that air will flow in direction of arrow stamped on body. Install as near as possible to equipment being serviced.

**Adjustment**

To unlock R20 adjustment, push knob down (in) to forward most position. Turn knob clockwise to increase the reduced or regulated pressure and counter-clockwise to lower pressure. On R21, loosen T-Handle lock nut and follow same directions. With relieving-type regulators, the reduced pressure follows adjustment of the knob. With non-relieving regulators, adjustment for low reduced pressure will not be obtained until the reduced pressure is "bled-off" or until air flow starts. To lock adjustment, simply pull knob to rearward position. If tamperproof adjustment is required, remove knob completely.

**Maintenance – Cleaning**

To clean, it is not necessary to remove regulator from the line. Refer to drawing as a guide in reassembly. If the air supply is kept clean, the regulator should provide long periods of uninterrupted service. Erratic regulator operation or loss of regulation is usually due to dirt in the disc area. To clean, shut off air line pressure, vent pressure, unscrew bottom plug and remove, inspect and clean disc. Clean parts with alcohol and blow out body with compressed air. When reassembling, make sure the disc stem fits into center hole of piston assembly. To clean or replace piston and/or adjustment spring, back off adjustment knob, depress spring cage retainer (lock), rotate cage approximately 45° and remove. Repeat procedure to reassemble cage. For servicing or replacement, depressurize unit first and then simply remove insert retaining pins and remove unit from air line as shown below.

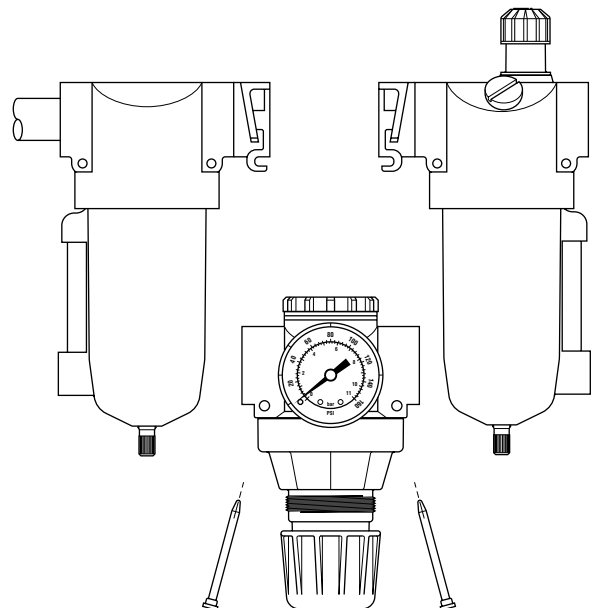

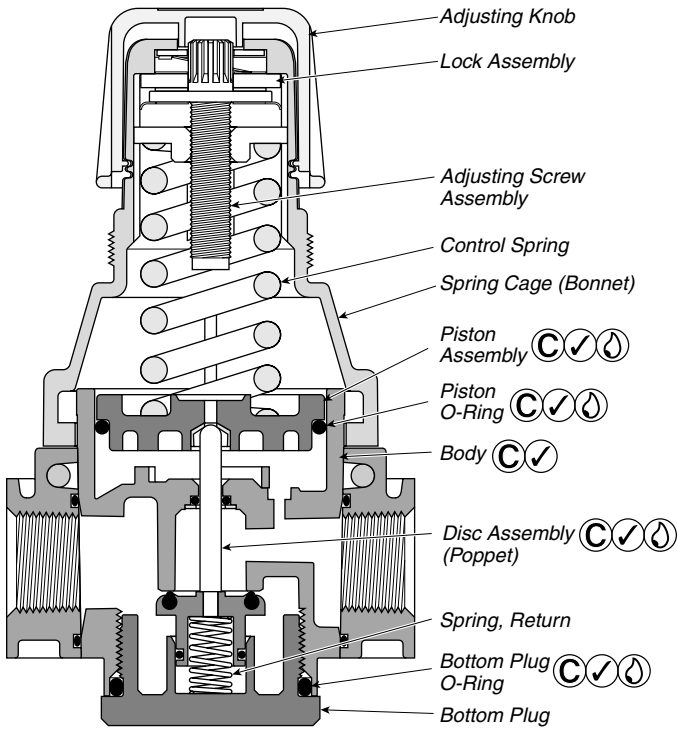

R20

- ⚠ Lightly grease with provided lubricant.
- ✓ Inspect for nicks, scratches, and surface imperfections. If present, reduced service life is probable and future replacement should be planned.
- C Clean with lint-free cloth.

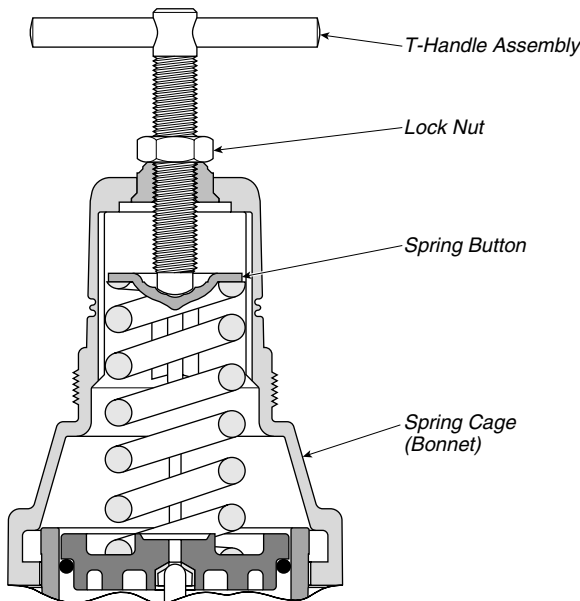

R21

### Service Kits / Parts Available

Description	Kit Number
Spring Cage and Knob Kit (Lock Assembly, Adjusting Screw, Adjusting Nut, Knob, Spring Cage)	CKR20A
Spring Cage / T-Handle Kit (Spring Cage, T-Handle Assembly, Lock Nut, Spring Button)	CKR21Y
Repair Kit (Piston Assembly and Disc Assembly) Relieving Non-Relieving	RKR20A/M1 RKR20KA/M1

### Accessories

Description	Kit Number
Panel Mount Kit	SAR20A57
Wall Mount Kit	MK20-0100

### Extra (Pipe Port) Insert Kits and Combination Unit Interface Insert

Pipe Port Size	Kit Number
1/4"	IK20Y
3/8"	IK20X
1/2"	IK20A
3/4"	IK20B
1"	IK20C
Combination	IK20CC

Note: Kit includes two pipe port inserts. "O" rings and pins.

### Regulator Types

- Type R20, R21 (Relieving)
- Type R20K, R21K (Non-Relieving)

### ⚠ WARNING

**FAILURE OR IMPROPER SELECTION OR IMPROPER USE OF THE PRODUCTS AND/OR SYSTEMS DESCRIBED HEREIN OR RELATED ITEMS CAN CAUSE DEATH, PERSONAL INJURY AND PROPERTY DAMAGE.**

This document and other information from The Company, its subsidiaries and authorized distributors provide product and/or system options for further investigation by users having technical expertise. It is important that you analyze all aspects of your application, including consequences of any failure and review the information concerning the product or systems in the current product catalog. Due to the variety of operating conditions and applications for these products or systems, the user, through its own analysis and testing, is solely responsible for making the final selection of the products and systems and assuring that all performance, safety and warning requirements of the application are met.

The products described herein, including without limitation, product features, specifications, designs, availability and pricing, are subject to change by The Company and its subsidiaries at any time without notice.

**EXTRA COPIES OF THESE INSTRUCTIONS ARE AVAILABLE FOR INCLUSION IN EQUIPMENT / MAINTENANCE MANUALS THAT UTILIZE THESE PRODUCTS. CONTACT YOUR LOCAL REPRESENTATIVE.**